

***EE-331***  
***Devices and Circuits 1***  
***Laboratory Handbook***

©

*Original: March 1993*  
*Revision 1: Sept. 1993*  
*Revision 2: Sept. 1994*  
*Revision 3: Sept. 1996 by W. T. Dietze*  
*Revision 4: March 2000*  
*Revision 5: Sept. 2004*  
*Revision 6: Sept. 2005*

*Prof. Robert B. Darling*  
*Dept. of Electrical Engineering*  
*Box 352500*  
*University of Washington*  
*Seattle, WA 98195-2500*

## Contents

---

	page
I. Organization, Hardware and Policies	
1. Introduction	5
2. Calendar for the Quarter	6
3. Location and Time Slots	7
4. Laboratory Groups	7
5. Laboratory Grading	8
6. Electronic Instrumentation	9
7. Parts Kits	15
8. Replacement Parts	18
9. Laboratory Notebooks	18
10. How to Use the Experimental Procedures	19
11. Errata, Improvements, and Acknowledgements	20
II. The Experiments	
0. Laboratory Preliminaries and Data Acquisition using LabVIEW (E0)	
P1. Transformer voltages	E0.3
P2. Internal resistance of the lab transformer	E0.5
P3. Create a curve tracer with your oscilloscope!	E0.7
P4. Oscilloscope input resistance	E0.9
P5. When is a wire not a wire?	E0.10
P6. Temperature measurement using LabVIEW and a DAQ card	E0.12
P7. Adding a Celsius to Fahrenheit conversion	E0.17
P8. Saving the measurement results to spreadsheet files	E0.18
1. 2-Terminal Device Characteristics and Diode Characterization (E1)	
P1. Measurement of diode reverse leakage current	E1.2
P2. Measurement of diode forward turn-on voltage	E1.4
P3. Measurement of diode I-V characteristics using the oscilloscope	E1.6
P4. Effect of series and parallel resistances	E1.9
P5. Measurement of diode I-V characteristics using LabVIEW	E1.11
P6. Measurement of a zener diode	E1.16
P7. Characterization of a light-emitting diode (LED)	E1.17
P8. Characterization of a photoconductive cell	E1.18
P9. Diode switching transients	E1.19
2. Diode Circuit Applications (E2)	
P1. Voltage clipper circuits	E2.1
P2. Voltage limiter circuits	E2.4
P3. Precision half-wave rectifier	E2.6
P4. Half-wave rectifier and capacitive filtering	E2.7
P5. Full-wave bridge rectifier and capacitive filtering	E2.9

*Organization, Hardware and Policies*

P6.	Zener diode voltage regulator	E2.11
P7.	Voltage clamper circuits	E2.13
P8.	Voltage multiplier circuits	E2.14
3.	JFET and MOSFET Characterization	(E3)
P1.	Discrete MOSFET lead, sex, and mode identification	E3.3
P2.	Integrated MOSFET lead, sex, and mode identification	E3.7
P3.	Measurement of a MOSFET using a LabVIEW curve tracer	E3.10
P4.	Measurement of CMOS pairs using a LabVIEW curve tracer	E3.15
P5.	Output conductance effects	E3.18
P6.	JFET gate lead, sex, and mode identification	E3.19
P7.	Measurement of a JFET using a LabVIEW curve tracer	E3.20
P8.	JFET variable attenuator	E3.22
4.	FET Driver, Load, and Switch Circuits	(E4)
P1.	E-mode MOSFET driver with resistor load	E4.3
P2.	E-mode MOSFET driver with D-mode load device	E4.6
P3.	D-mode JFET driver with resistor load	E4.7
P4.	CMOS inverter circuit	E4.8
P5.	CMOS Schmitt trigger circuit	E4.9
P6.	Create a VTC curve tracer using LabVIEW and a DAQ card	E4.11
P7.	CMOS inverter VTC measured using a LabVIEW curve tracer	E4.17
P8.	3-input CMOS NAND gate	E4.19
P9.	CMOS analog switch characteristics	E4.20
P10.	CMOS analog switch logic circuits	E4.23
P11.	Flying capacitor voltage inverter	E4.25
P12.	Voltage step-up switch-mode power supply	E4.27
P13.	Sample and hold gate	E4.29
5.	CMOS Timing, Logic, and Memory Circuits	(E5)
P1.	NAND and NOR gate truth table verification	E5.2
P2.	Manual combinatorial logic analyzer using LabVIEW	E5.6
P3.	Automatic combinatorial logic analyzer using LabVIEW	E5.9
P4.	Non-latching monostable circuit	E5.12
P5.	Latching monostable circuit	E5.14
P6.	CMOS square wave oscillator	E5.16
P7.	Logic function implementation design	E5.18
P8.	Hardwired D-type flip-flop	E5.19
P9.	Asynchronous frequency divider circuits	E5.20
P10.	Synchronous finite state machine	E5.22
P11.	Push-on/push-off circuit	E5.25
P12.	CMOS ring oscillator	E5.27
III.	The Design Project: Information and Guidelines	(D1)
1.	Overview of Electronic Circuit Design	D1.1

*Organization, Hardware and Policies*

- |    |                              |      |
|----|------------------------------|------|
| 2. | Design Project Guidelines    | D1.3 |
| 3. | Design Project Documentation | D1.4 |

## *Introduction*

---

- Purpose** Skill in electronic circuit design is based mostly upon one's intuition about the manner in which electronic devices operate, and upon how they interact when interconnected in a circuit. Contrary to popular belief, the entire process of engineering design does not take place behind the screen of a computer. The computer is only a tool which is used to manage mundane bookkeeping chores and to eliminate the most obvious errors. All of the computer-aided design (CAD) software packages presently in existence only provide bookkeeping assistance and do not eliminate the need for creativity from the designer. This creativity must come from one's intuition. Thus, the primary purpose of this laboratory is to start the process of training one's intuition about electronic circuits.
- Skills** In addition, laboratory experience is necessary for building certain skills that are needed in electrical engineering. These skills include the proper and knowledgeable use of electronic instrumentation, the ability to prototype designs, the ability to make certain routine measurements, and perhaps most importantly, the ability to troubleshoot and correct problems in designs which did not work as planned. These skills, like the creative spark itself, are not obtained from rote mathematical analysis of the theory, nor do they come from hours of flagellation with computer software. These skills and creativity instead come from “hands-on” interaction with the subject matter in question, which is of course what the laboratory provides.
- Hacking** The usefulness of the laboratory will be enhanced if a hacking attitude is adopted. By this is meant an open-minded attitude of liberally trying out new thoughts without a lot of mathematical analysis, library reference, or computer simulation. Learn to make solder your programming language! Learn not to trust any schematic until you see it working properly in front of you! Learn to distrust SPICE! Learn to not trust that you have the correct wire in your hand until you have traced back to find where the other end is going. Electronic component parts are for the most part cheap and easily replaceable. Don't be afraid to push them to their limits or blow a few up in the quest for your new design.

*Calendar for the Quarter*

---

Overview            The laboratories are intended to occur on a regular cycle of once per week over the 10 weeks of the quarter. There is no laboratory activity the first week. Laboratory work begins on a normal schedule starting the second week, with a first meeting to get acquainted with the teaching assistant and to perform some “warm-up” procedures with the lab equipment. After the 5 main laboratory experiments have been completed, the remainder of the quarter is reserved for development of the design project. It is expected that the design project should not carry over into finals week.

- Week-1            No laboratory meeting
- Week-2            Experiment-0 and introduction to the lab and the T.A.
- Week-3            Experiment-1
- Week-4            Experiment-2
- Week-5            Experiment-3
- Week-6            Experiment-4
- Week-7            Experiment-5
- Week-8            Open lab time for design project
- Week-9            Open lab time for design project
- Week-10           Open lab time for design project
- Week-11           Finals Week: all labs should be completed before this

Reminders

My T.A. is		
My Lab Section is		
My Lab Time Slot is		
My Lab Partners are		

### *Location and Time Slots*

---

Location	The laboratory will be held in Room 137 of the EE1 (EE/CSE) Building.
Time Slots	<p>Each laboratory section is allocated one 3-hour block of time per week. Due to the heavy use of the Room 137 laboratory by other sections, and by other classes as well, it is not possible to schedule time other than the pre-arranged weekly slot.</p> <p>In order to get the most out of your laboratory time, you should read through the experimental procedures ahead of time to familiarize yourself with what needs to be done. Some of the experiments require a good deal of set-up, and you will need to move through the procedures expediently in order to finish them all.</p>

### *Laboratory Groups*

---

Groups	The overall EE-331 class is divided into laboratory sections of nominally 24 students each. The resources presently available in the Room 137 laboratory only provide 8 complete test benches. Therefore, the students of each laboratory section must work in 8 groups of 3 members each. Because of the limited availability of equipment, this group size must remain fixed.
Teamwork	It is rare in modern engineering for engineers to work completely by themselves. In order to see a project through to its completion, an engineer must interface with other engineers, managers, and technicians. It is a good idea to start now (in this laboratory) in applying the basic ideas of working within a group or team. These ideas include dividing up the tasks among team members, managing the tasks so that they all are finished in concert with one another, and most importantly, getting along peacefully with the rest of the team throughout the process.
Who Does What	In small groups of 3 members, it is important for everyone to participate equally. The situation where one person does all of the work and the others simply stand around and watch should be avoided at all cost. Your group should set up some method to rotate around between members who are recording data, manipulating the instruments, reading instructions, or constructing or modifying the breadboards.

## *Laboratory Grading*

---

- Experiments Each of the 5 experiments are weighted equally and are graded completely from the write-up in the laboratory notebook. Experiment-0 is not graded. The T.A. will only grade that part of the lab notebook which pertains to the “Question-X” part which is asked within a given procedure. The rest of the notebook entries are for your use. Consequently, you should put the answers to the asked questions inside a highlighted box in your notebook so that the T.A. can more easily find them. This is described later on in this handbook. Each student of the group must submit a laboratory notebook, and the scores are assigned individually, not to the group as a whole.
- Design Project The design project, which occupies the last 3 weeks of the laboratory, will involve a combined effort from the group as a whole. Each group will submit one set of design documents (described later) and will demonstrate one working version of their circuit. The score received on the design project will be composed from the design documentation (50 percent) and from how well the actual prototyped circuit performs, as demonstrated to the T.A. (50 percent). Each member of the group will receive the same score for the design project.
- Lab Grade The lab grade will be composed from the score on the experiment write-ups in the lab notebook (60 percent) and from the score on the design project (40 percent). Even though the laboratory provides only 1 credit hour out of the 5 credits for the class, the laboratory grade will count 30 percent toward your final class grade to emphasize its importance.

## Electronic Instrumentation

---

Quality	Electronic instrumentation is becoming increasingly more sophisticated each year. The laboratory in Room 137 is fortunate to have most of its equipment donated from Hewlett-Packard, Tektronix, Fluke, and National Instruments. The generosity of these companies has created a laboratory which is far superior to that which would have been possible with Washington State funds alone. This equipment is generally state-of-the-art, and what one should expect to find in a well-equipped electronics laboratory of a future employer.
Operation	Each piece of equipment has many different operational modes, features, and functions, and to learn how to use all of these could take several days for each instrument. Nevertheless, there are some basic operations on each instrument that you should learn as quickly as possible. Presumably, some of the more basic operational procedures have already been encountered in previous EE laboratory courses. It is highly recommended to spend some time during the first lab meeting (week 2; see calendar) to familiarize yourself with the given instruments and how to configure them for their most basic functions.
Configuring	Setting up an instrument to perform a given function is termed <i>configuring</i> the instrument. In the laboratory procedures, you will be instructed to configure certain instruments to produce a given function, for example, “configure a DMM to measure voltage at the output node of the circuit.” From this, you must be able to properly connect the test leads and program the instrument from its front panel to produce this function. Since the specific instruments may vary from bench to bench, you will not be given any specific instructions for the instruments.
Handling	Each piece of electronic instrumentation in the Room 137 laboratory is a precision instrument, and each should be treated as such. It is very important to think through what you are doing and consider the consequences before you actually start the procedure. Unlike software manipulation, where one can freely hack away without regard to consequence, playing around with real voltages and currents can lead to serious damage, either to the test circuit components, the instrument itself, or occasionally to the operator. This is particularly true with signal generators and power supplies.
Problems	One fact of life is that equipment breaks from time to time. If you think that your particular instrument is not working properly, first contact the T.A. Do not try to fix any equipment yourselves. Also, do not move equipment from bench to bench without first consulting the T.A.
Specifications	For purposes of perspective, listed below are some of the advertised specifications on the various pieces of instrumentation available in the Electrical Engineering Department laboratories.

*Organization, Hardware and Policies*

HP-3114A	Function Generator. (\$4800 replacement cost) Lin/log sweep, gate, counted burst, AM/FM/VCO, HP-IB, 1/2 cycle mode, arbitrary waveform gen., phase lock $\times N$ , $\div N$ , sine, square, and triangle 1mHz - 20 MHz, 0-10 V <sub>pp</sub> into 50 $\Omega$ , pulses and ramps to 2 MHz with 5-95 % symmetry.
HP-3312A	Function Generator. (\$1600 replacement cost) 0.1 Hz - 13 MHz, sine, triangle, ramp, pulse, AM, FM, sweep, triggered, and gated, 80:20:80 % symmetry, 50 $\Omega$ outputs, 20 V <sub>pp</sub> into open circuit, $\pm 10$ V DC offset, <20 ns pulse edges
HP-33120A	15 MHz Function / Arbitrary Waveform Generator. (\$1725 cost) Sine, square, triangle, and ramp waveforms, AM, FM, FSK, and burst modulation, linear and log sweeps, 80:20:80 symmetry, 12 bit $\times$ 16k arbitrary waveform generator @ 40 MS/s
HP-3478A	Digital Multimeter. (\$995 replacement cost) 3-1/2 to 5-1/2 digit accuracy, 100 nV resolution, true rms, 4-wire ohmmeter, HP-IB, electronic calibration, 90 readings/sec, 300 kHz bandwidth, 4:1 crest factor, autoranging.
HP-34401A	Digital Multimeter.
HP-35660A	Dynamic Signal Analyzer. No longer manufactured.
HP-3582A	Spectrum Analyzer. No longer manufactured.
HP-E3630A	Triple Output DC Power Supply. 0 to +6 V @ 2.5 A, 0 to +20 V @ 0.5 A, and 0 to -20 V @ 0.5 A,
HP-6236B	Triple Output Power Supply. (\$900 replacement cost) 0 to +6 V @ 2.5 A, 0 to +20 V @ 0.5 A, and 0 to -20 V @ 0.5 A, 35 W total, constant voltage with current limit, dual tracking
HP-6255A	Dual DC Power Supply. (\$1900 replacement cost) 0-40 V, 0-1.5 A, 0-60 W, constant voltage/constant current modes, automatic cross-over, floating output (for each side).
HP-6632A	System DC Power Supply. (\$1700 replacement cost) 0 to +20 V, 0 to $\pm 5$ A, 100 W max output, HP-IB controllable, sink or source current, constant voltage, constant current, remote sensing, overvoltage & overcurrent protection
HP-8116A	50 MHz Pulse / Function Generator. (\$4400 replacement cost) 1 mHz - 50 MHz, 32 V <sub>p-p</sub> on all waveforms, sine, triangle, square,

*Organization, Hardware and Policies*

haverfunction, and DC waveforms, 10 ns minimum pulse width, 6 ns pulse transitions, 90:10:90 duty cycle,  $\pm 8$  V DC offset

- HP-8904A Multifunction Synthesizer. (\$2950 replacement cost)  
DC-600 kHz sinewaves, DC-50 kHz triangle, ramp, and square, 12-bit direct digital synthesis, AM, FM,  $\phi$ M, and PM capability, dual output, floating outputs (1 k $\Omega$ ), Gaussian white noise gen., HP-IB, phase and frequency synchronization to other units.
- HP-54501A 100 MHz Digitizing Oscilloscope. (\$3465 replacement cost)  
DC to 100 MHz repetitive, DC to 1 MHz single shot, 4-channel, 3.5 ns risetime, 5 mV - 5 V/div, 1 M $\Omega$ , 16 pF inputs,  $\pm 250$  V max, channels 1&4 use full attenuator, channels 2&3 use limited atten., 2 ns to 5 s/div timebase, cursors, menu driven
- Seiko-DPU-411 Type II Thermal Printer.
- Tek-TDS320 100 MHz / 500 MS/s Two Channel Oscilloscope.
- Tek-Sony 370 Programmable Curve Tracer. (\$18950 replacement cost)  
10 A @ 16 V, 2 A @ 80 V, 0.4 A @ 400 V, 0.05 A @ 2000 V, GPIB interface, 100 nA to 2 A/div collector supply, 5 mV to 500 V/div collector, 5 mV to 2 V/div base supply, 50 nA to 200 mA/step, 50 mV to 2 V/step step generator, 100 points/div digital storage, on-screen cursors, annotation, waveform comparison, dot cursor, waveform averaging
- Tek-571 Curve Tracer. (\$2950 replacement cost)  
0.5-100 V, 0-2 A @ 50 V, 0-1 A @ 100 V collector supply, 0.25-10 k $\Omega$  load resistors, 0.1-1.0 V/step gate drive, 0.5  $\mu$ A - 20 mA/step base drive, 5  $\mu$ A - 200 mA/div vertical, menu driven, hardcopy output, EEROM, on-screen cursors.
- Tek-2232 Digital and Analog Oscilloscope. (\$5495 replacement cost)  
100 MHz analog, 100 MS/s digital, dual time base, 10 ns capture, 1k - 4k record length, 8-bit vertical resolution, V-t cursors, IEEE-488 bus, 2 mV - 5 V/div vertical, 0.5 s - 50 ns/div timebase.
- EE-331 Laboratory Transformers. (\$50 replacement cost, less assembly)  
These have been built expressly for use in the EE-331 laboratory experiments, but may be used by some other classes as well. Each delivers  $\pm 6.3$  VAC rms at 2.0 Amps maximum ( $\pm 7.5$  VAC rms open circuit;  $\pm 10.6$  VAC peak). A schematic and bill of materials for the lab transformer appears on the next two pages.

EE-331 Laboratory Transformer Schematic:

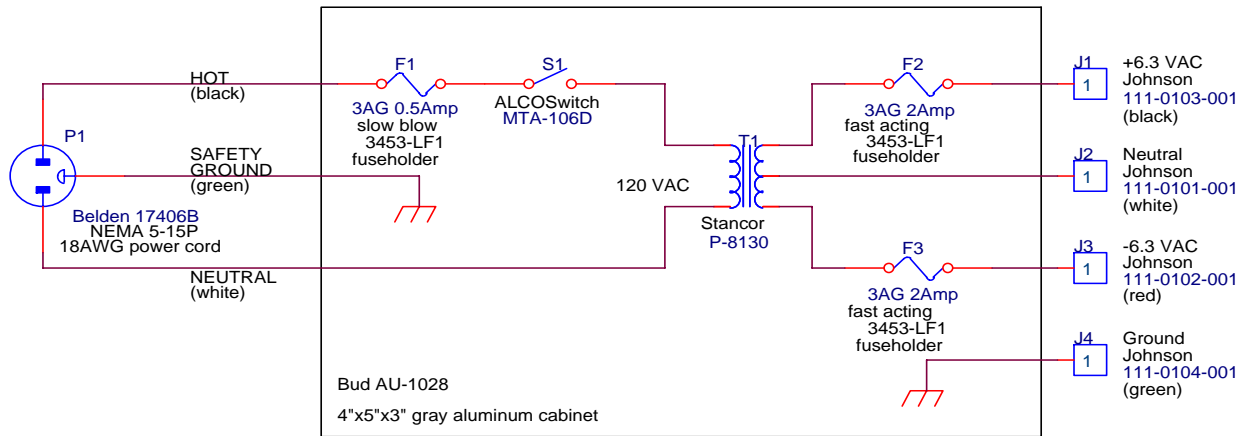

Output = +/- 6.3 Vrms @ 2.0 Amps  
 Output = +/- 7.5 Vrms @ open circuit

screw terminal/banana sockets  
 on std. 0.75" spacing

Robert B. Darling Device Electronics Laboratory Department of Electrical Engineering, Box 352500 University of Washington Seattle, Washington 98195 U.S.A.		
Title EE-331 Lab Transformer		
Size A	Document Number LXFMR331	Rev 1A
Date: Friday, March 17, 2000	Sheet 1	of 1

*Organization, Hardware and Policies*

EE-331 Laboratory Transformer Bill of Materials:

<b>Bill of Materials</b>						
<b>EE-331 Lab Transformer</b>						
<b>Design # LXFMR331-Rev. A1</b>						
R.B.Darling, 1993/6/5						
Identifier	Manufacturer	Part Number	Description	Quantity	Price Each	Subtotal
T1	Stancor	P-8130	120VAC:12.6 CT@2A, 25VA power transformer	1	\$11.25	\$11.25
S1	ALCOSwitch	MTA-106D	SPDT 120V@6A switch	1	\$3.60	\$3.60
F1	Littelfuse	3AG 0.5 A	slow blow fuse	1	\$0.87	\$0.87
F2,F3	Littelfuse	3AG 2.0 A	fast acting fuse	2	\$0.25	\$0.50
P1	Belden	17406B	black PVC NEMA 5-15P three-wire power cord	1	\$5.39	\$5.39
J1	Johnson	111-0103-001	black banana/screw jack	1	\$1.44	\$1.44
J2	Johnson	111-0101-001	white banana/screw jack	1	\$1.44	\$1.44
J3	Johnson	111-0102-001	red banana/screw jack	1	\$1.44	\$1.44
J4	Johnson	111-0104-001	green banana/screw jack	1	\$1.44	\$1.44
	Littelfuse	3453-LF1	3AG fuse holder	3	\$1.72	\$5.16
	Bud	AU-1028	4"x5"x3" aluminum cabinet	1	\$12.80	\$12.80
			Subtotal for each unit:			\$45.33
			8.2 % sales tax			\$3.72
			Subtotal with tax:			\$49.05
			Total for EE-331 labs:	12	\$49.05	\$588.56

*Organization, Hardware and Policies*

List of Equipment Needed for each of the Experiments

Experiment-0	Laboratory Preliminaries digital multimeter EE-331 $\pm 6.3$ VAC laboratory transformer oscilloscope DC power supply Computer running LabVIEW 7.1 NI PCI-6251M DAQ card and cable NI CB-68LP or CB-68LPR connector block
Experiment-1	2-Terminal Device Characteristics and Diode Characterization digital multimeter EE-331 $\pm 6.3$ VAC laboratory transformer oscilloscope DC power supply Computer running LabVIEW 7.1 NI PCI-6251M DAQ card and cable NI CB-68LP or CB-68LPR connector block
Experiment-2	Diode Circuit Applications EE-331 $\pm 6.3$ VAC laboratory transformer DC power supply oscilloscope digital multimeter
Experiment-3	JFET and MOSFET Characterization digital multimeter DC power supply Computer running LabVIEW 7.1 NI PCI-6251M DAQ card and cable NI CB-68LP or CB-68LPR connector block
Experiment-4	FET Driver, Load, and Switch Circuits DC power supply digital multimeter function generator oscilloscope
Experiment-5	CMOS Timing, Logic, and Memory Circuits DC power supply function generator oscilloscope

***Parts Kits***

---

**Purchase**            Each laboratory group must purchase one standard kit of parts for the EE-331 laboratory experiments. This kit contains all of the necessary parts which will be used in the five experiments. The parts kit is not intended to supply all of the parts which may be needed in the design project; these are an additional purchase. The parts kits may be purchased from the E.E. Stores, room 147 of the EE1 building. Parts can be purchased through the E.E. Stores window which opens into the room 137 laboratory. It is suggested that the members of the laboratory group divide up the cost of the parts between themselves.

**Contents**            The standard-issue EE-331 parts kit should contain the following:

Quantity	Industry Part Number	Description	EE Stores Part Number	EE Stores Price (Each)
1		Resistor, 100 $\Omega$ , 1/4 W, 5%	RBD0-100	
1		Resistor, 470 $\Omega$ , 1/4 W, 5%	RBD0-470	
3		Resistor, 1.0 k $\Omega$ , 1/4 W, 5%	RBD3-1.0	
1		Resistor, 4.7 k $\Omega$ , 1/4 W, 5%	RBD3-4.7	
7		Resistor, 10 k $\Omega$ , 1/4 W, 5%	RBD3-10	
1		Resistor, 20 k $\Omega$ , 1/4 W, 5%	RBD3-20	
1		Resistor, 33 k $\Omega$ , 1/4 W, 5%	RBD3-33	
3		Resistor, 100 k $\Omega$ , 1/4 W, 5%	RBD3-100	
1		Resistor, 220 k $\Omega$ , 1/4 W, 5%	RBD3-220	
1		Resistor, 1.0 M $\Omega$ , 1/4 W, 5%	RBD6-1.0	
2		Resistor, 10 M $\Omega$ , 1/4 W, 5%	RBD6-10	
1		Resistor, 100 $\Omega$ , 1/4 W, 1%	RCD0-100	
3		Resistor, 1.0 k $\Omega$ , 1/4 W, 1%	RCD3-1.0	
6		Resistor, 10 k $\Omega$ , 1/4 W, 1%	RCD3-10	
3		Resistor, 100 k $\Omega$ , 1/4 W, 1%	RCD3-100	
1		Resistor, 1.0 M $\Omega$ , 1/4 W, 1%	RCD6-1.0	
1		Potentiometer, 10 k $\Omega$ , 1 turn	T34-103	
1		Potentiometer, 100 k $\Omega$ , 1 turn	T34-104	
4		Capacitor, 33 pF, ceramic disk	CC0-33	
4		Capacitor, 220 pF, ceramic disk	CC1-22	
4		Capacitor, 0.001 $\mu$ F, ceramic disk	CC2-10	
1		Capacitor, 0.047 $\mu$ F, ceramic disk	CC3-47	
6		Capacitor, 0.1 $\mu$ F, ceramic disk	CC4-10	
6		Capacitor, 10 $\mu$ F, 25 V, electrolytic	CE6-10	
1		Capacitor, 33 $\mu$ F, 25 V, electrolytic	CE6-33.25	
1		Inductor, 100 mH	I4-10	
2	1N34A	Diode, Germanium	1N34A	
2	1N4148	Diode, Silicon, high speed switching	1N4148	
6	1N4007	Diode, Silicon, rectifier, 1000 V, 1 A	1N4007	
3	1N4732	Diode, Zener, 4.7 V	1N4732	
2	1N4744	Diode, Zener, 15 V	1N4744	
2	1N5819	Diode, Silicon Schottky, 40 V, 1 A	1N5819	
1	HT-32	Diac, Silicon, 27-32 V	HT-32	
4	LN28RP (Panasonic)	LED, red, GaAsP, T1-3/4 (5 mm), 700 nm, 0.8 mcd @ 15 mA, 2 V	LN28RP	

*Organization, Hardware and Policies*

1	VT-301 (EG&G VacTec)	Photoconductive cell, CdSe	VT-301	
2	MPF102	JFET, n-channel, D-mode	MPF102	
1	2N7000	MOSFET, n-channel, E-mode, 60 V	2N7000	
1	CD4001	IC, quad 2-input NOR gate	CD4001	
1	CD4007	IC, CMOS array	CD4007	
1	CD4011	IC, quad 2-input NAND gate	CD4011	
2	CD4013	IC, dual D-type flip-flop	CD4013	
1	CD4016	IC, quad analog switch	CD4016	
1	MC1458	IC, dual operational amplifier	MC1458	
1	LM35DZ	IC, Centigrade temperature sensor	LM35DZ	
1		Potentiometer trimming tool		
1		Spool of #22 AWG solid hook up wire		
1		Plastic compartmented box		

## *Organization, Hardware and Policies*

**Breadboards** At least one superstrip (solderless breadboard) will be required for the laboratory. If you already have one of these from a previous laboratory, there is no need to buy a second one. The E.E. Stores will sell parts kits either with, or without, the superstrip breadboards.

The \$10.00 superstrip uses 770 alloy contacts which is generally satisfactory for all purposes in this lab. Those with wealthy parents may wish to flaunt their social status and buy the gold-plated contact version for about \$35.00. These are available to the gullible at many of the local electronics parts stores.

**Test Leads** The laboratory in Room 137 only maintains the following test leads for each bench:

- Two 10× oscilloscope probes
- Two BNC(m)-to-BNC(m) coaxial cables
- Two BNC(f)-to-dual alligator clip leads
- Assorted banana plug(m)-to-banana plug(m) jumpers

Many of these test leads have a tendency to wander from their proper point of use. To help reduce your irritation level, you are strongly suggested to buy and maintain your own set of test leads. These can be either made up yourself, or purchased from the stockroom.

The premier version consists of a male banana plug on one end and a squeeze-hook on the other. A less expensive version is to make a set of leads from #22 AWG solid wire and put a banana plug on one end. Simply stripping off 1/4" of insulation from the other end will provide a connection that can be plugged into the tie points on the solderless breadboards. Cheaper still (but least convenient) is to just use #22 AWG solid wire and attach the end that would have the banana plug to the banana jack on the instruments (when possible).

**Handling Parts** The CMOS integrated circuits and the discrete MOSFET's are static sensitive devices which are quite easily destroyed by careless handling. The discrete MOSFET's in particular are extremely sensitive because they do not contain any internal protection diodes. All of these parts should be stored on the black conductive foam until they are needed. Make sure that you are grounded when you remove any of these parts from the foam, so as to avoid possible electrostatic discharge (ESD) damage. Also, make certain that your circuits are connected properly before applying power to them.

## *Replacement Parts*

---

**Kablooey!** You are responsible for replacing any parts that you blow out as a result of either static or improper circuit connections. The E.E. Stores is not responsible for ensuring that you have working parts. In addition, they will not accept back used parts for a refund. Static sensitive CMOS devices are a fact of modern electronics. Part of the purpose of this laboratory is to train you in how to successfully handle and employ these devices.

## *Laboratory Notebooks*

---

**Notetaking** 60 percent of the laboratory grade is derived from the laboratory notebook. This notebook is intended to look and function as a running scratchpad for your experimental lab work. It does not have to be particularly pretty, but it does need to be legible enough for the T.A. to make sense out of it. Laboratory notebooks are not designed to be taken home and recopied; you should learn to write clearly and legibly on the fly. In the long term, this will save you a lot of time.

**What to Include** In general, you should include anything that you want to remind yourself about in the future. These can be calculations, instrument settings and/or unusual characteristics, measurement results, circuit schematics, or specific conclusions from the experiments.

**What to Highlight** For purposes of grading, the T.A. will only be looking for answers to each of the “Question-X” sections, which appear within each of the experimental procedures. The remainder of the lab notebook is for your own use and will not count for or against your notebook grade. As a result, you should put a colored or highlighted box around each place in your notebook which responds to the “Question-X” section so that the T.A. can more easily locate it. In general, if it is not highlighted or circled with an obvious box, the T.A. is under no obligation to count it.

**Two Notebooks** In general, the T.A. will attempt to grade and return each experiment within 2 weeks or so. However, the labs run each week, so there exists a problem in getting the graded lab notebook back to each student in time for the next lab session. To fix this problem, it is suggested that you use two notebooks, and alternate lab experiments between them. This way, the T.A. can be grading one notebook while you are working with the other.

## *How to Use the Experimental Procedures*

---

Organization	<p>Each of the 6 laboratory experiments consists of a set of procedures. For the overall experiment to make the most sense, the procedures should be performed in the order that they are listed. To help the T.A. in understanding your laboratory notebook, you should reference each set of questions to the number of the corresponding procedure.</p> <p>Each procedure is roughly divided into sections of Set-Up, Measurements, Questions, and Comments. These are consistently indicated on the left-hand side of the page.</p>
Set-Up	<p>The set-up section explains how to assemble the breadboard, how to configure the instruments, and generally how to put things together so that a measurement can be made.</p>
Measurement-X	<p>The measurement section tells what to measure. Usually this section will also suggest certain specific measurement values to be included in your notebook. The “X” refers to the procedure number of the experiment, and is helpful to the T.A. to understand your notebook.</p>
Question-X	<p>The question section asks specific inquiries that you are to answer in your notebook. These may be simple one-word answers, short explanations, or occasionally, a bit of data reduction to be performed. In each case, however, the questions are something that you do not need to answer in the lab itself. If you are good about recording every measurement that is asked for in the “Measurement-X” section, your notebook should have all of the raw data that you will need to answer these questions at a later time (outside of the Room 137 laboratory). This should be remembered if laboratory time gets short. The “X” also refers to the procedure number and is helpful to the T.A. when grading your notebook.</p>
Comment	<p>Comment sections are purely for your perusal and amusement. Occasionally, they contain some fun-facts that may help in various procedures.</p>
Which Ones?	<p>Each of the lab experiments includes many procedures, but due to time limitations, you are not expected to work through all of them. The class instructor will assign specific procedures from each of the experiments prior to your actual lab time slot. Which procedures that are assigned will vary from quarter to quarter. However, if you have finished all of the assigned procedures, you are certainly free to explore any of the remaining ones with any extra time that you may have.</p>

*Errata, Improvements, and Acknowledgements*

---

Errata            Despite best efforts, there most likely exist errors in this laboratory manual: possibly incorrect instrument settings, schematic errors, incorrect part values, and/or simply silly instructions. The best proofreading will undoubtedly be by the class using this handbook, so it is YOU who should tell the author about the mistakes. The plan is for this laboratory handbook to be regularly revised. Please send your uncovered errors to:

Prof. R. B. Darling  
Dept. of Electrical Engineering  
Box 352500  
University of Washington  
Seattle, WA 98195-2500

or send e-mail to:

[bdarling@ee.washington.edu](mailto:bdarling@ee.washington.edu)

Improvements    Likewise, if you have any suggestions for improvements in this laboratory handbook, the procedures contained therein, or the laboratory itself, I welcome your comments. Please send them to me at either of the above addresses. I would also welcome any suggestions for new procedures to be added to the existing set of experiments.

Thanks!            The author is indebted to the many previous students of EE-331 who have contributed their careful suggestions (and relentless complaints) as these have helped immeasurably to make this laboratory handbook more effective.

Thanks are also extended to Dr. W. T. Dietze, who taught EE-331 during the 1996-97 academic year, and who contributed the initial versions of procedures 0.1, 0.2, 0.3, 0.4, 0.5, 2.2, 2.3, 3.7, 4.9, 4.10, and 4.11.